

Clarke®

METALWORKER



WARNING: Read these instructions before using the bender

710mm METAL BENDER

MODEL NO: CMB710

PART NO: 7610905

OPERATION & MAINTENANCE INSTRUCTIONS

ORIGINAL INSTRUCTIONS

GC06/23

INTRODUCTION

Thank you for purchasing this CLARKE Metal Bender. Before attempting to use it please read this manual and carefully follow all instructions given. In doing so you will ensure the safety of yourself and that of others around you, and you can also look forward to the product giving you long and satisfactory service. Ensure the product suffered no damage during transit and that all items are present. Should any loss or damage become apparent, please contact your CLARKE dealer immediately.

Dimensions D x W x H	155 x 902 x 128 (+420mm handle) mm		
Net Weight	17.9 kg		
Bending Capacity	Thickness-1.2mm	Width 730mm	Angle - 0-90°

SAFETY PRECAUTIONS

As with all tools and workshop equipment it is necessary to exercise caution when it is put to use, being aware of any associated or inherent dangers.

- Due to the weight of the metal bender, the help of an assistant may be beneficial during unpacking and mounting.
- ALWAYS operate on a suitably strong bench with adequate light.
- This metal bender must be firmly secured to a firm and level bench using suitable bolts (not supplied).
- Leave adequate working space around the bender for safer and convenient operation.
- ALWAYS check for signs of structural damage before starting work. DO NOT use if damage is found. Have repairs made only by a CLARKE service centre.
- ALWAYS ensure the workpiece is secure and properly positioned before applying pressure.
- ALWAYS keep hands and fingers away from moving parts that may pinch.
- NEVER use extension tubes to increase the length of the handles. Excessive effort can cause damage and/or accidents.
- NEVER attempt to bend materials which exceed the sizes stated above.

Failure to heed these warnings may result in damage to the equipment or personal injury.

METHOD OF USE

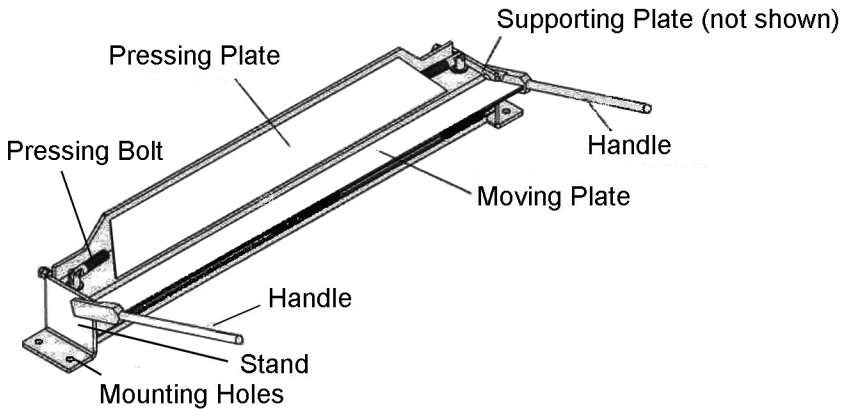

Mount the Metal Bender on a sturdy workbench at a height which allows easy operation taking into account the nature of the work, with the handles pointing towards you.

- 4 x10 mm bolts will be required (not supplied) for mounting to the chosen bench. Holes will need to be drilled in the bench at the positions shown.

WARNING: NEVER EXCEED THE MAX BENDING CAPACITY (1.2mm MATERIAL).

1. Lower the handle until the moving plate becomes parallel to the workbench.
2. Position the workpiece on the supporting plate and the moving plate so that the edge to be bent lines up with the back edge of the supporting plate.
3. Place the pressing plate on top of the supporting plate so that the back edge of the Pressing Plate lines up flush with the back edge of the Supporting Plate.

NOTE: To ensure a proper bend, leave a 2-3mm gap for 1.2mm material, decrease the gap when using thinner material. Experiment with scrap pieces.

4. Raise the two handles to bend the material.

WARNING: WHEN BENDING SHEET METAL, KEEP YOUR HANDS CLEAR OF THE SUPPORTING AND MOVING PLATE TO AVOID INJURY.

If disposing of scrap metal, DO NOT dispose of with general waste. Metal products and scrap should be taken to your local civic amenity site for the recycling of metal products according to local regulations.

A SELECTION FROM THE VAST RANGE OF

Clarke®

QUALITY PRODUCTS



AIR COMPRESSORS
From DIY to industrial, Plus air tools,
spray guns and accessories.

GENERATORS
Prime duty or emergency standby
for business, home and leisure.

POWER WASHERS
Hot and cold, electric and engine
driven - we have what you need

WELDERS
Mig, Arc, Tig and Spot.
From DIY to auto/industrial.

METALWORKING
Drills, grinders and saws for DIY
and professional use.

WOODWORKING
Saws, sanders, lathes, mortisers
and dust extraction.

HYDRAULICS
Cranes, body repair kits,
transmission jacks for all types of
workshop use.

WATER PUMPS
Submersible, electric and engine driven
for DIY, agriculture and industry.

POWER TOOLS
Angle grinders, cordless drill sets,
saws and sanders.

STARTERS/CHARGERS
All sizes for car and commercial use.

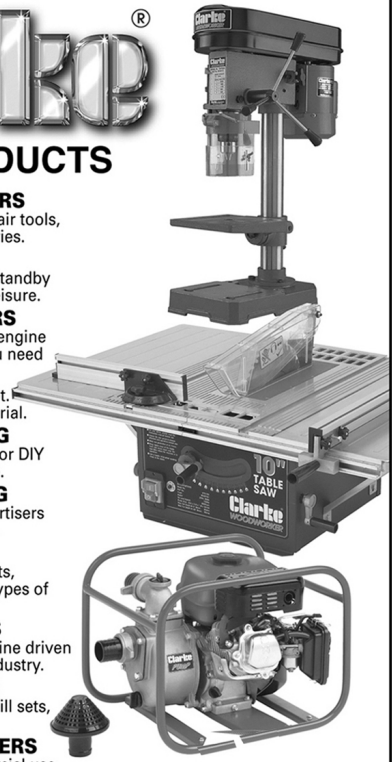

Guarantee

This product is guaranteed against faulty manufacture for a period of 12 months from the date of purchase. Please keep your receipt which will be required as proof of purchase.

This guarantee is invalid if the product is found to have been abused or tampered with in any way, or not used for the purpose for which it was intended. Faulty goods should be returned to their place of purchase, no product can be returned without prior permission.

This guarantee does not affect you statutory rights.

PARTS & SERVICE: 020 8988 7400

E-mail: Parts@clarkeinternational.com or Service@clarkeinternational.com

SALES: UK 01992 565333 or Export 00 44 (0)1992 565335

Clarke® INTERNATIONAL Hemnall Street, Epping, Essex CM16 4LG
www.clarkeinternational.com